

SPECIFICATIONS	
CONTACT CARRIER MATERIAL	TPU
MOLDED HEAD MATERIAL/COLOR	TPU/YELLOW
CONTACT MATERIAL/PLATING	BRASS/GOLD
COUPLING NUT MATERIAL/PLATING	BRASS/NICKEL
RATED CURRENT [A]	9.0 A
RATED VOLTAGE [V]	600 V
OUTER JACKET MATERIAL/COLOR	PVC/YELLOW
NUMBER OF CONDUCTORS [AWG]	4x18 AWG
CONDUCTOR INSULATION MATERIAL	PVC
TEMPERATURE RATING	-40°C to +105°C (-40°F to +221°F)
PROTECTION CLASS	NEMA 1,3,4,6P,12 & IECIP67, IP68,IP69,IP69K

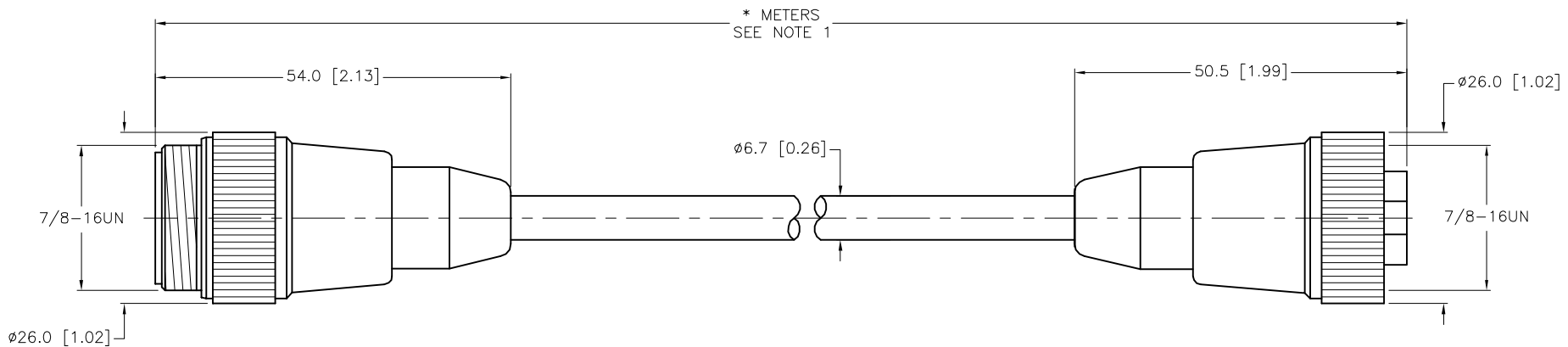

CABLE LENGTH	TOLERANCE*
ALL LENGTHS	+ 4% (OR 50mm) OF LENGTH - 0% (OR 0mm) OF LENGTH WHICHEVER IS GREATER
STRIP LENGTH	TOLERANCE*
0-7mm	±0.5mm
8-29mm	±1.0mm
30-49mm	±2.0mm
50-69mm	±3.0mm
70-100mm	±4.0mm
OVER 100mm	±5.0mm

***UNLESS OTHERWISE SPECIFIED**

NOTES:

- "*" INDICATES CABLE LENGTH IN METERS. CONTACT TURCK TO ORDER SPECIFIC LENGTHS.
- "/S824" DESIGNATES PLTC CABLE HAVING CSA "FT-4" FLAME RATING.

SOURCE DRAWING - FOR REFERENCE ONLY

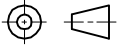
RELATED DOCUMENTS 1. 2. 3. 4.	3RD ANGLE PROJECTION 	THIS DRAWING IS CONFIDENTIAL AND THE PROPERTY OF TURCK INC. USE OF THIS DOCUMENT WITHOUT WRITTEN PERMISSION IS PROHIBITED.		3000 CAMPUS DRIVE MINNEAPOLIS, MN 55441 1-800-544-7769 (763) 553-7300 (763) 553-0708 fax www.turck.us	
		MATERIAL SEE SPECIFICATIONS	DRFT MJM APVD	DATE 12/18/06 SCALE 1=1.0	DESCRIPTION RSM RKM 40-*M/S824
FINISH SEE SPECIFICATIONS	ALL DIMENSIONS DISPLAYED ON THIS DRAWING ARE FOR REFERENCE ONLY CONTACT TURCK FOR MORE INFORMATION	UNIT OF MEASUREMENT MILLIMETER [INCH]		IDENTIFICATION NO.	
DO NOT SCALE THIS DRAWING		FILE: 777002843		REV E	

E	UPDATE PROTECTION CLASS	CBM	04/13/21	76628
REV	DESCRIPTION	BY	DATE	ECO NO.